

Application:

AV42-110 is a halfwave dipole with a reflector utilized for farfield monitoring of ILS-localizer and for VOR-monitoring. Weather protection is achieved by embedding all conductors in glassfibre reinforced tubes. Cavities are filled with polyurethane foam.

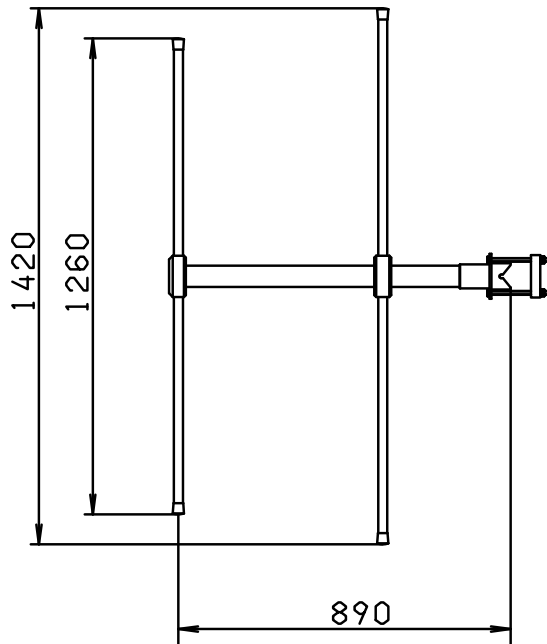

Dimensions in mm.

Electrical specifications:

Frequency range	108-112 MHz
Nominal impedance	50 ohm
Power rating	50 W
Gain	6.5 dBi
Front/back ratio	9 db
Polarization	Linear
Connector	N-connector female
VSWR	< 1.5

Mechanical specifications:

Design	Halfwave dipole. Radiating elements completely enclosed in polyurethane foam within a fiberglass tube. Hot dip galvanized mounting hardware.
Dimensions	see drawing
Weight	4.6 kg
Wind rating	55 m/s = 125 mph
Finish	Polyurethane lacquer, white
Temperature range	-55 °C, +55 °C; -67 °F, +131 °F

Mounting:

The AV42-110 antenna is easily mounted to tube 2"-3". The mounting hardware is suitable for both horizontal and vertical polarization.

Suitable cable: RG8, RG213 or similar.

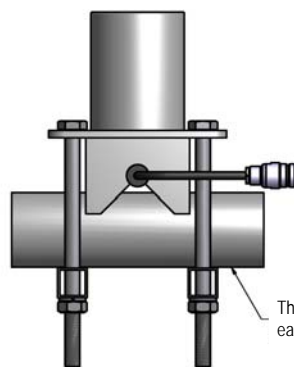
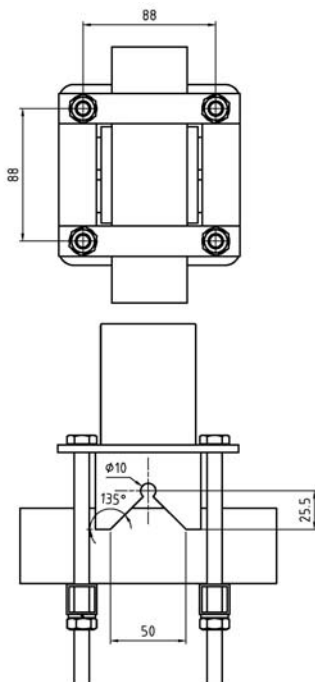

The AV42-110 antenna is easily mounted to tube 2"-3"

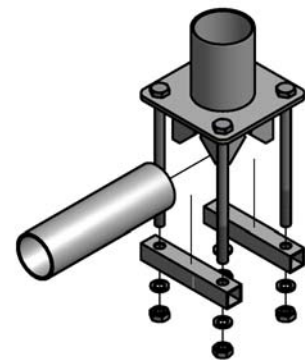

The mounting hardware is suitable for both horizontal and vertical polarization