

The Comrod family of CAPAS® Automatic Payload Alignment Systems are designed to meet the challenges faced by public safety, defence and demanding industrial users. CAPAS® systems enables quick and effective deployment of communication or sensor assets in extreme environments without exposing personnel to unnecessary danger.

CAPAS-SR-2 Single Rotator System accomplishes this by enabling 360 degree azimuth rotation of a wide range of payloads.

CAPAS-SR-2 supports both closed loop and open loop alignment, and allows a combination of both. In closed loop alignment mode the system is controlled by a radio transceiver to optimize received signal strength or minimize bit error rate. In open loop alignment mode the system is controlled by the Comrod Integrated Mission Planning System. The powerful drive system coupled with the optional fully integrated GPS compass allows fast and accurate positioning of payloads demanding better than 1.5 degree pointing accuracy. Closed loop feedback from the radio can optimize the alignment within a fraction of a degree.

CAPAS-SR-2 is fully rugged per MIL-STD-810, and is suitable for a wide range of deployable masts, including Comrod TM, LMT and ULM series.

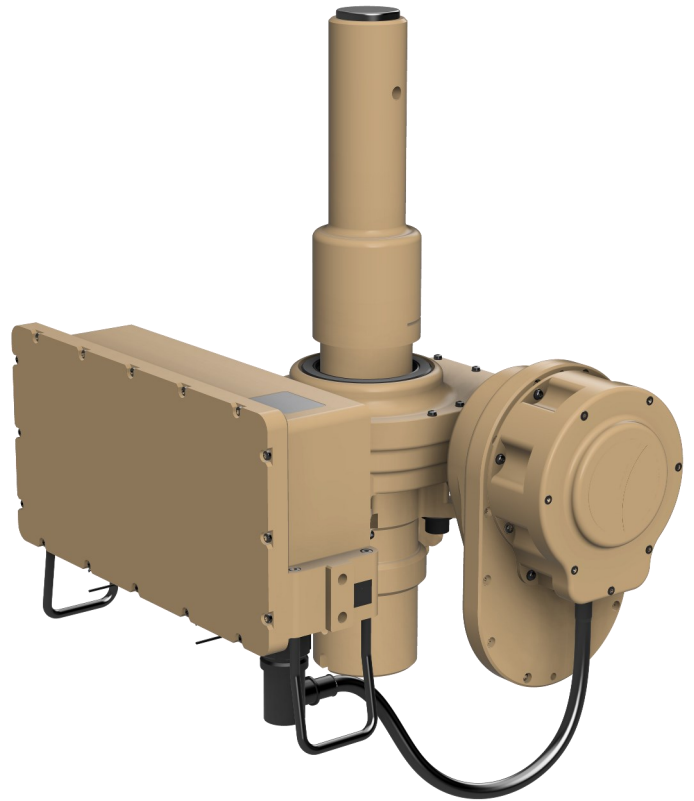

### Features

Power Supply	18 to 54 VDC (MIL-STD 1275E @ 28 VDC)
Alignment Modes	Closed loop mode with transceiver control Open loop mode with magnetic or DGPS compass control Hybrid mode
Planning Tool (Optional)	Integrated Mission Planning System
Pointing Accuracy	~ 0.5 degree relative to base
Rotating Speed *	> 10 degrees per second *
Operating Temperature (Ambient)	-40°C to +60°C (-40°F to 140°F)
Torque *	>50 Nm Dynamic *, >250 Nm Static (survival)
Payload Capacity *	20 kg (maximum in-balance load) *
Dimensions (nominal)	W = 32 cm, H = 43 cm, D = 31 cm (12.6 x 17 x 12.2 in)
Weight (nominal)	10.6 kg (23.3 lbs)
Mounting	Lower socket, 50.5 mm, 100 mm deep. Upper mounting spigot 50 mm, 140 mm long. Adaptors are available for a wide range of payloads and masts

\* Dependent on power supply and payload weight/area

Characteristic	Standard
Interfaces	CAN, RS232, RS485 or Ethernet (not all available together)
Vehicle Power	MIL-STD 1275E
EMC/EMI	MIL-STD-461F CE102, RE102, RS103, CS101, CS114, CS115, CS116 and CS117
Wind Rating (Max)	150 km/h (94 mph), when fitted with typical Comrod Band 4 antennas (see below)
Operating Temperature	Ambient: --40°C to +60°C (-40°F to 140°F)
Encapsulation	IP67 MIL-STD-810G, Method 506.5, Procedure I, for rain and blowing rain MIL-STD-810G Method 512.5, Procedure I, for complete immersion at 1 m depth
Solar Radiation	MIL-STD-810G, Method 505.5, Procedure I (4 x 24h exposure)
Salt Fog	MIL-STD-810G Method 509.5 (> 96h)
Icing / Freezing Rain	MIL-STD-810G, Method 521.4 (ice thickness = 6mm)
Sand and Dust	MIL-STD-810G METHOD 510.5 Procedure I and II
Altitude	Operational - MIL-STD-810G: Method 500.5, Procedure II, 4572 m (15000 ft) at 57.2 kPa Storage - MIL-STD-810G: Method 500.5, Procedure I, 12192 m (40000 ft) at 18.8 kPa
High temperature	Operation: MIL-STD-810G, Method 501.5, Procedure II , 60°C Storage: MIL-STD-810G, Method 501.5, Procedure I, 71°C
Low temperature	Operation: MIL-STD-810G, Method 502.5, Procedure II, - 40°C Storage: MIL-STD-810G, Method 502.5, Procedure I, -51°C
Humidity	MIL-STD-810G, Method 507.5, Procedure II, Aggravated
Vibration *	MIL-STD-810G, Method 514.6C Table 514.6C-VI. Composite wheeled vehicle vibration exposures figure 514.6C-3 *
Shock *	MIL-STD-810G, Method 516.6, Procedure I, functional Shock, 12g 11ms *

\* Unit without payload. Permanent mount required for high shock/vibration environments

### Mounting Details

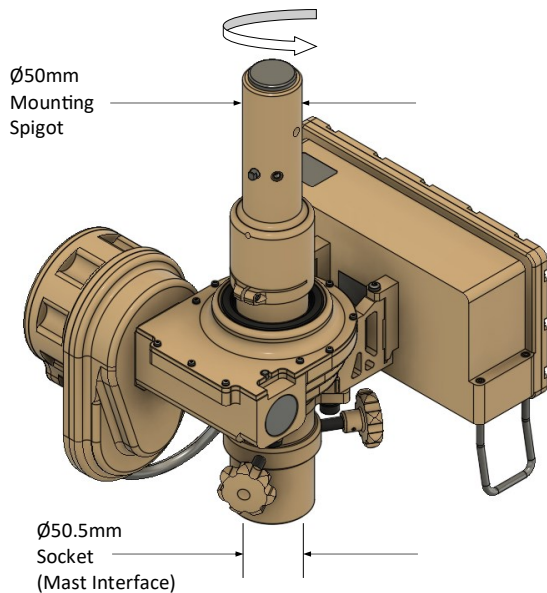

### Outline Drawing

